



X Series Reachstacker
with capacities of 45,000kg

STAGE V
CERTIFIED

REACH
THE SKY



HANGCHA GROUP CO., LTD.

Factory site: 666 Xiangfu Road,
Hangzhou, Zhejiang, China (311305)

Tel: +86-571-88926735 88926755
Fax: +86-571-88926789 88132890

sales@hcforklift.com
www.hcforklift.com



Follow us on
Facebook



Follow us on
YouTube



Follow us on
WeChat



Available on the
App Store



Download "Hangcha
Forklift" App



ISO 45001
ISO 45001:2018



ISO 14001
ISO 14001:2015



ISO 9001
ISO 9001:2015



HANGCHA trucks conform
to the European Safety
Requirements.

HANGCHA GROUP CO., LTD. reserves the right to make any changes without notice concerning colors, equipment, or specifications detailed in this brochure, or to discontinue individual models. The colors of trucks, delivered may differ slightly from those in brochures.

2026 VERSION 1/COPYRIGHT 2026/03

The World of Hangcha
SINCE 1956





X SERIES REACHSTACKER

The RS4531CH-XRW86 Reachstacker is a newly developed product based on Hangcha's X series platforms. Inheriting the appearance of the X series family, it is fashionable, high-end and powerful. Using key parts of internationally renowned brands, it has excellent performance and guaranteed quality.

Using advanced control technologies, it is safe, reliable, comfortable and efficient. It is mainly used in the loading, handling and stacking operations of 20' and 40' ISO heavy containers and meets the requirements for high-intensity and long-term operations of containers at ports, docks, railway and highway transfer stations, storage yards, etc.

Safe and reliable

- / **Durable and reliable high-quality key parts of internationally renowned brands.**
- / **Rich safety equipment**
6-probe visual reverse radar, lock camera, eccentric load weighing system, vehicle fire protection and other equipment enable safe and easy operations.
- / **Comprehensive safety protection technologies**
Safety technologies such as seat sensing, dynamic anti-tipping protection, longitudinal dual anti-tipping protection, spreader twist-lock dual protection, startup anti-stalling protection, fault protection, etc. are used to ensure safe operations at all times.

Easy maintenance

- / CAN bus communication monitors the vehicle status in real time, which is convenient troubleshooting.
- / The easy-to-remove hood is designed. All the maintenance points are in easily accessible and safe positions and the electric control cabinet wiring method is adopted, which greatly simplifies the maintenance and repair and improves the maintenance efficiency.

Energy-saving and efficient

- / **Efficient control systems**
Electric proportional control, throttle following control, vertical lift control, intelligent cooling fan control and torque control enable efficient and flexible control.
- / **Hydraulic load sensing system**
Through real-time adjustment of pump displacement in accordance with the load, high-precision flow control is realized, non-operating energy consumption of the engine is reduced and a significant energy saving effect is achieved.
- / **Vehicle LED lighting system**
The high-performance and long-life vehicle LED lighting system can reduce energy consumption.



Strong power system



KESSLER

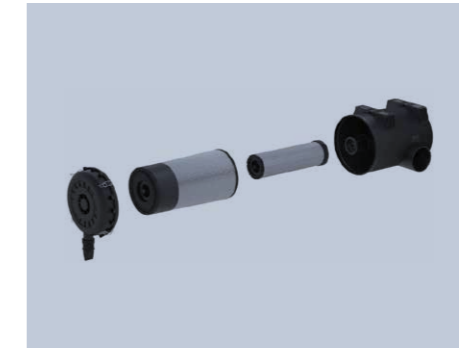

DONALDSON



VOLVO TAD1151VE

- / With high performance and low fuel consumption, the low-speed high-torque VOLVO TAD1151VE engine has advanced fault diagnosis and fault protection functions. With a displacement of 10.8L, six in-line cylinders and low emission, it is turbocharged and meets EPA3, EU III A and China Stage III emission requirements.
- / Equipped with a Donaldson two-stage heavy-duty air filter and a high-efficiency cyclone pre-filter.
- / DANA36000 gearbox with a reliable structure and stable performance
- / German KESSLER's heavy-duty reinforced drive axle, two-stage decelerating and with a multi-disc wet driving brake, the brake oil filtration system and the independent brake oil cooling system are adapted to heavy-duty operation conditions.
- / The 800L super-large fuel tank meets the requirements of continuous and long-term work and saves working time.



DANA36000

Stylish and comfortable

- / **Fashionable and high-end modeling elements**
The pitch-down streamlined design presents a vivid and sturdy profile. Smooth coloring and the simple and elegant logo highlight fashionable and high-end design elements.
- / **Ergonomic control platform**
The ergonomically-designed control platform equipped with reasonably-arranged comfortable-feel buttons enables comfortable and accurate operations, plus the adjustable steering wheel and the suspended seat with an adjustable backrest, making the operator more comfortable.
- / **Quiet, fully-suspended all-round vision cab**
In the cab, noises are less than 78dB and there are a cooling and heating air conditioner, sunshades, a reading light, a radio and other equipment to provide a comfortable operating environment, plus the largely-curved front and rear windows, large glass ceiling and all-glass side doors to enable a broad view.



Comprehensive electrical safety system



- / A 24V electrical system, a 110A AC generator, a main power switch, and a cab emergency switch
- / Advanced CAN bus communication is used to acquire the working status of the input / output execution components of the engine, gearbox, spreader and vehicle and then display the data on the high-definition color screen, which is convenient for the operator to view. Fault protection can avoid safety accidents.
- / Dynamic anti-tipping protection control system:
Overload protection: the boom stops moving in the dangerous direction but can move in a safe direction.
- Load indicator:**
 - lit green (indicating that the system can work normally);
 - lit orange (indicating that system is warning for particular attention);
 - lit red (indicating that the system is detecting a situation requiring immediate action)
- Display:** boom length, actual load, maximum load, boom height, jaw angle, outreach, load percentage bar, alarm code, etc.
- / Concentratedly-controlled lighting system
A concentratedly-controlled lighting system, an integrated button panel and comfortable-feel control switches enable comfortable and easy operations. The LED lighting system is controlled by the CAN bus and has short-circuit and open-circuit diagnosis functions.

Fully-suspended all-round vision cab

- / The suspended cabin, easy for maintenance.
- / With the vehicle frame damper connected and the tight sound and heat insulation design, most vibration and noise are shielded.
- / The largely-curved front and rear windows, all-glass left and right doors and large glass ceiling enable a broad view.
- / An inclinable telescopic steering column and fully-suspended adjustable seat with a high backrest and safety belt, with seat sensing and driving position sensing functions
- / A high-power cooling and heating air conditioner, two ventilation modes - internal and external circulation, sunshades, speed-adjustable wipers and defrosting function make driving more comfortable.



ELME new-generation container spreader



- / For the new-generation ELME817 series telescopic container spreader, the design of the telescopic beam, turntable, etc. are optimized, so that the structural strength is increased, the weight of the spreader is 16% less than that of the spreader of the last generation and the service life is prolonged by 30%.
- / The arrangement of the oil cylinder is changed to be more conducive to maintenance.
- / Design of the hydraulic system is optimized, so that the spreader system has less pressure loss and is more energy-saving and efficient.
- / With electro-hydraulic proportional control, the speed is adjustable and the rotation angle of the spreader can be smoothly and finely controlled.
- / The latest Neuron programmable controller is used so that more optional features can be developed. Fault code information is provided according to the J1939 protocol so that fault query is quick and simple.
- / The twist-lock interlock device (mechanical and electro-hydraulic) and the real-time indication of the action indicator are provided to avoid:
 - the container is lifted when less than 4 corners are locked;
 - the twist-lock is opened when the container is lifted.
- / The lift interrupter can prevent the container from being lifted when the twist-lock is partly twisted. The lift operations can be performed only when the twist-lock is locked or unlocked.

Efficient hydraulic system

- / American PARKER's combined hydraulic valves, Danish DANFOSS's variable hydraulic pump and the load sensing hydraulic system, reduce the continuous load of the engine.
- / Flexible and precise electric proportional control.
- / Light load high-speed lifting increases work efficiency.
- / Independent temperature control and the large-size hydraulic oil cooler meet the work in the environment of up to 50 degrees.
- / Perfect high and low pressure oil filters improve the reliability of the hydraulic system.
- / Multiple hydraulic test points are set to simplify repair and maintenance work.





Vehicle cooling management

- / Fans with electronic motors are used independently to cool hydraulic oil and brake oil, so that the requirements for use in the 50-degree high temperature environment are met.
- / Torque converter oil temperature control management ensures that the gearbox works within the optimal temperature range.
- / High-power plate-fin heat dissipaters and suction fans with large cooling strength and low noise are used for the intercooling and cooling liquids, so that the requirements for use in the 50-degree high temperature environment are met.



Appearance and performance

- / The pitch-down streamlined design of the vehicle presents a vivid and sturdy profile.
- / The optimized counterweight contour greatly reduces the turning radius of the vehicle, broadens the side rear and front rear views, and makes driving simple and safe.
- / The left and right stair handrails, mudguard handrails, together with the anti-skid pedals and anti-skid paper, fully protect the safety of personnel.



Features

	Standard	Options
Transmission		
Pneumatic tyre	●	
Solid smooth tyre		○
Steering system		
Fully hydraulic power steering	●	
Centralized lubrication system (machine)	●	
Automatic Lubrication System		○
Power system		
Extended exhaust pipe	●	
Lockable fuel cap	●	
Spark arrester		○
Pre-cleaner air filter	●	
Truck		
Tow pin	●	
Electrostatic discharge chain		○
Rear-view mirror on right & left mudguards	●	
Separate brake oil tank	●	
Operating system		
Integrated joystick	●	
Adjustable steering column	●	
Adjustable armrest	●	
Hydraulic system		
Variable hydraulic pump system	●	
Operation proportion control	●	
Higher lifting speed at light load	●	
Cab		
Cabin	●	
Climate control system (air-conditioning and heater)	●	
Radio	●	
Sunshade	●	
USB charging interface	●	
Clothes hanger hook	●	
Reading light	●	
1 x 24V power supply		○
1 x 12V power supply		○
License plate frame		○
Fan	●	
Lifting components		
Standard lifting height	●	
Spreader & twistlock double protection	●	
Emergency descent	●	
Twistlock counter	●	
Spreader swing prevention	●	
4 x Spreader twistlock camera		○
2 x Spreader twistlock light	●	
Other		
Standard color	●	
User defined colour		○
Fire extinguisher (2kg/4kg)		○
Vehicle toolkit	●	
Heating pack for the cold region		○
Automatic throttle control (lift / tilt / spreader)	●	
Lifting height indicator on display	●	
Dynamic speed Limit depending of lift height(customer defined)		○
FIMS(Fleet intelligent management system)	●	

Features

Electrical System	Standard	Options
Operator Presense System (OPS) with buzzer	●	
LCD display screen	●	
Main power switch	●	
Emergency power off switch	●	
Maintenance-free 24V lead acid battery	●	
Reverse buzzer	●	
High decible horn	●	
LED lights (entire vehicle)	●	
4 x Working light on front mudguard	●	
4 x Working light on boom	●	
2 x Rear working light	●	
Reverse sensor	●	
rearview camera system	●	
rearview camera system with memory		○
front & rearview camera system		○
front & rearview camera system with memory		○
4 directions camera system with single display		○
4 directions camera recording system with single display		○
In cabin CCTV		○
Rear blue safety light		○
Front and rear blue safety light		○
Three sided blue danger zone light		○
Overspeed alarm		○
Speed limitation		○
Voice reverse alarm		○
Automatic fire suppression system	●	
Two-way radio		○
Weight indicator in display	●	
Flashing warning light (non rotating) with control switch	●	
Eccentric load weighing (with printer)		○
Tyre pressure monitoring		○
On-board diagnostics system	●	
Vehicle Control Unit (VCU)	●	
Override switch	●	
central control panel for lighting system	●	
Torque limitation	●	
Vertical lift control		○
Engine fault alarm	●	
Engine oil pressure alarm indicator	●	
Air filter warning indicator	●	
Water temperature indicator	●	
Hour meter	●	
Battery charge indicator	●	
Low hydraulic pressure alarm indicator	●	
Hydraulic oil filter warning indicator	●	
Oil gauge	●	
Fuel-water separator warning indicator	●	
Oil temperature gauge	●	
Pre-heat indicator	●	
Drive mode indicator	●	
Parking brake indicator	●	
Service indicator	●	